

TRT-A-□N (For 100V)

Primary	0-100-110-120V
Secondary	0-100-110-120V

Winding : Double winding
 Insulation : Insulation class A
 Electrostatic shielding : With electrostatic shield

- Standard products
- Shingle phase
- Double winding

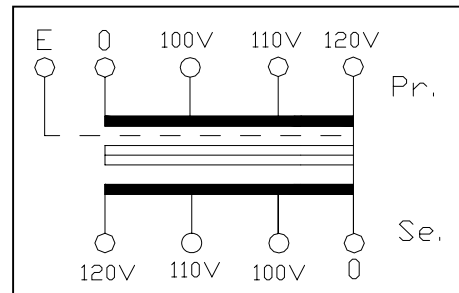

Wire connection

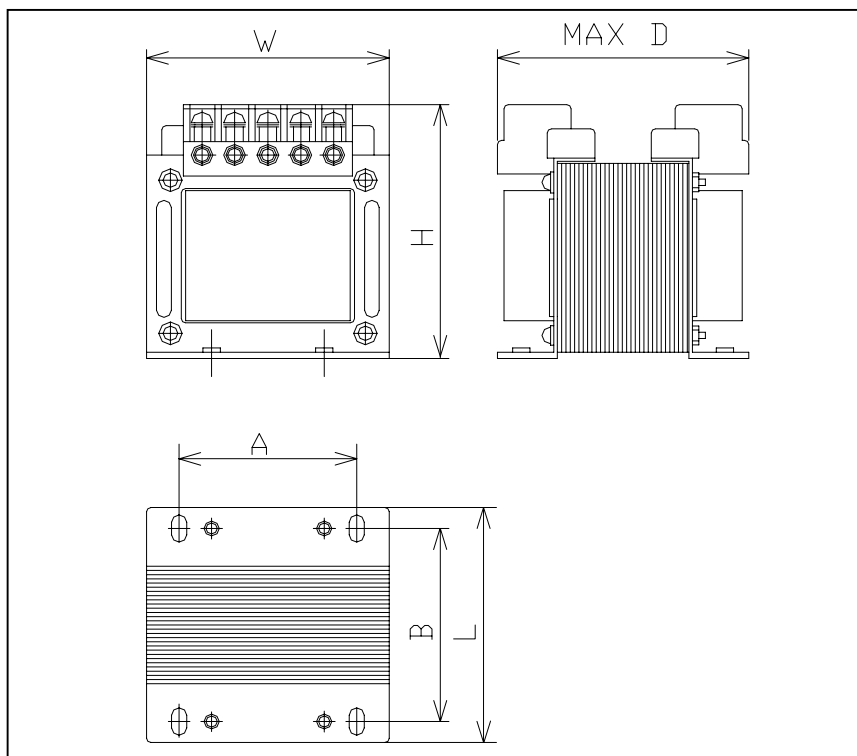

Type	Capacity (VA)	Secondary Current(A)	W	H	D	A	B	L	Weight (Kg)	Hole Size (mm)
TRT-A-100N	100	1	105	108	100	66	67	80	3	5.5 × 10
TRT-A-150N	150	1.5	105	112	105	75	69	85	3.7	5.5 × 10
TRT-A-200N	200	2	105	112	115	75	79	95	4.5	5.5 × 10
TRT-A-300N	300	3	114	116	125	75	87	105	5.3	5.5 × 10
TRT-A-500N	500	5	154	150	120	111	91	110	8.5	6.5 × 10
TRT-A-750N	750	7.5	154	150	135	111	101	120	10	6.5 × 10
TRT-A-1KN	1K	10	154	150	155	111	121	140	13	6.5 × 10

TRT-B-□N (For 200V)

Primary	0-200-220-240V
Secondary	0-200-220-240V

Winding : Double winding
 Insulation : Insulation class A
 Electrostatic shielding : With electrostatic shield

- Standard products
- Shingle phase
- Double winding

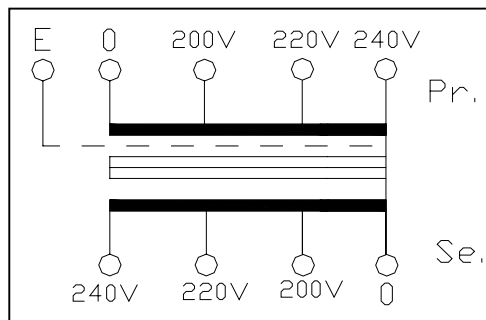

Wire connection

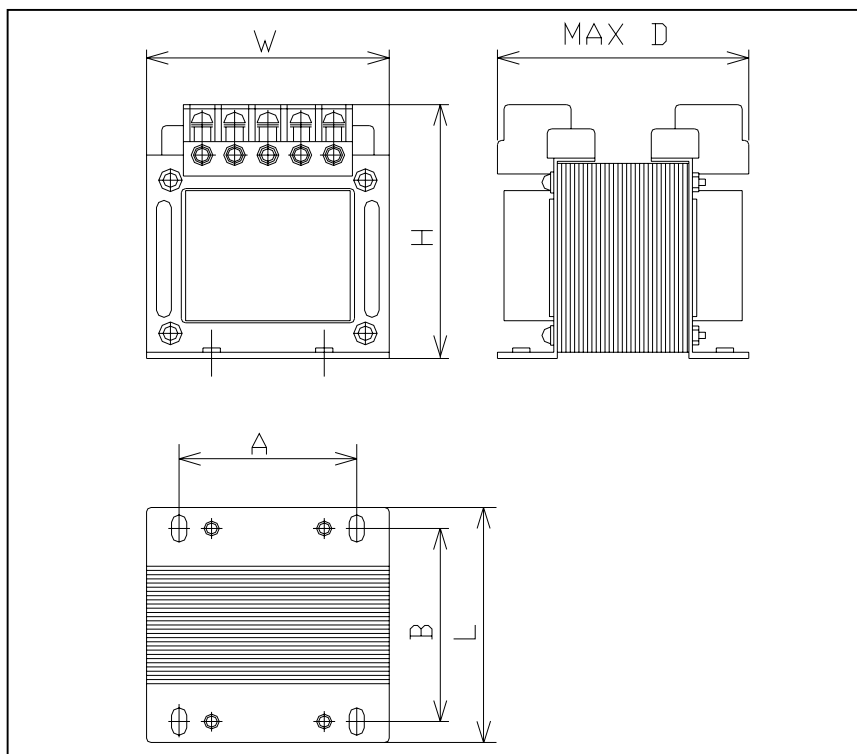

Type	Capacity (VA)	Secondary Current(A)	W	H	D	A	B	L	Weight (Kg)	Hole Size (mm)
TRT-B-100N	100	0.5	105	108	100	66	67	80	3	5.5 × 10
TRT-B-150N	150	0.75	105	112	105	75	69	85	3.7	5.5 × 10
TRT-B-200N	200	1	105	112	115	75	79	95	4.5	5.5 × 10
TRT-B-300N	300	1.5	114	116	125	75	87	105	5.3	5.5 × 10
TRT-B-500N	500	2.5	154	150	120	111	91	110	8.5	6.5 × 10
TRT-B-750N	750	3.75	154	150	135	111	101	120	10	6.5 × 10
TRT-B-1KN	1K	5	154	150	155	111	121	140	13	6.5 × 10